



ZANOTTI Spa
Via M.L. King, 30
46020 - Pegognaga (MN) - ITALY
Tel. +39 0376 5551
Fax +39 0376 536554
info@zanotti.com

Technical specifications

Version 1.35

Model:

BGM11202Y

Class:

Uniblock GM

Technical data

Characteristics	M.U.	Value
Working temperature	°C	-15 ÷ -25
Starting mode		Direct
Voltage	Volt-Ph-Hz	230/1~/50
Rated input	kW*	0,70
Rated input	Amp*	4,00
Peak current	Amp	29,0
Max current	Amp	7,2
Refrigerant		R290
Defrost		Hot gas
Mass	Kg	64

Compressor

Type		Hermetic
Nominal power	kW	0,9

Condenser

Air flow	m³/h	600
----------	------	-----

Evaporator

Air flow	m³/h	600
Air throw	m**	4

PED Category		0
--------------	--	---



Power data

Tc °C	Ta °C	P watt	P Kcal/h	V120 m³	V100 m³	V80 m³
	20	1149	988	8,6	7,6	6,7
	25	1099	945	8	7,1	6,2
-15	30	1049	903	7,3	6,5	5,7
	35	1000	860	6,8	6,1	5,3
	40	951	818	6,3	5,6	4,9
	45	898	772	5,6	5	4,4
	20	942	810	6,1	5,5	4,7
	25	908	781	5,7	5,1	4,5
-20	30	871	748	5,4	4,7	4,2
	35	830	714	4,9	4,4	3,8
	40	787	676	4,5	3,9	3,5
	45	741	638	4	3,6	3,1
	20	769	661	4,3	3,8	3,3
	25	738	634	4	3,6	3,1
-25	30	704	605	3,7	3,3	2,9
	35	667	574	3,4	3	2,7
	40	629	540	3	2,7	2,4
	45	588	505	2,7	2,4	2

* When normally running: -20 ÷ +30°C

** Use air throw as a base. Air throw is affected by many factors such as height of room, product storage, location of evaporator, etc.

Tc: Coldroom temp. - Ta: External temp.

P: Refrigerant capacity - V: Recommended cold-room volume

Dimensioni - Dimensions - Dimensions
Abmessungen - Dimensiones

GM1

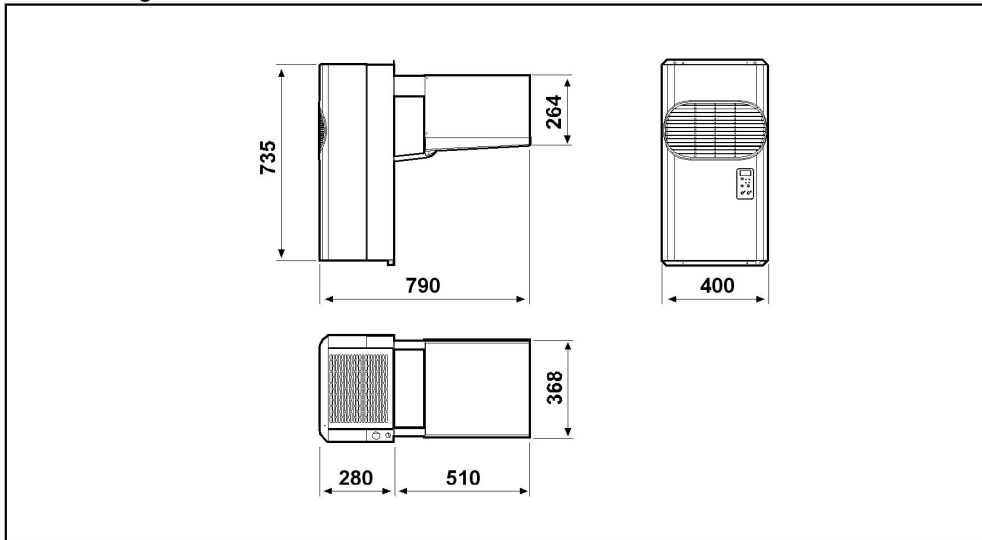

Schema di montaggio - Mounting scheme - Schema de montage
Montageschema - Esquema de montaje

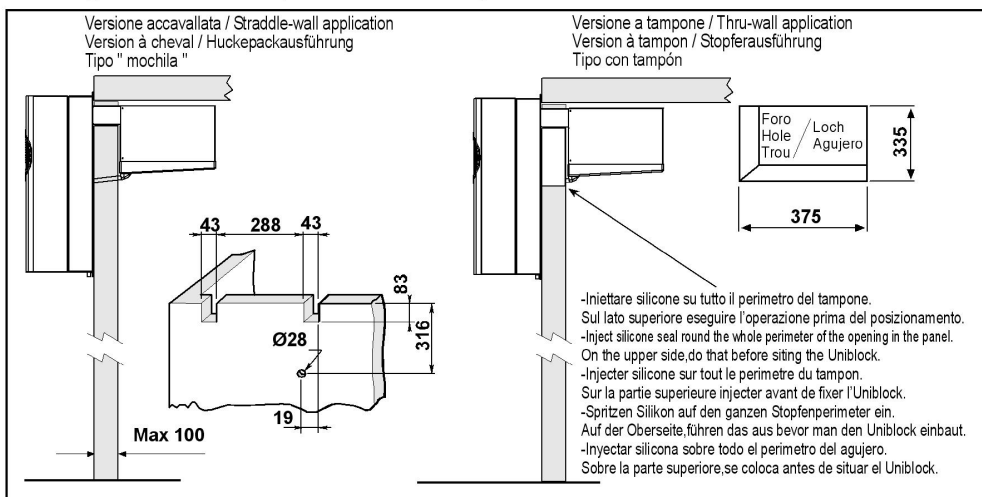

- * Raccomandazioni in sede di installazione e per il controllo fornite sul manuale di installazione
- * To be advised at time of order for factory installation and operating instructions
- * Recommendations au moments d'installations et pour le contrôle fournis sur le manuel d'installation
- * Empfehlungen für die Installationsphase und zur Kontrolle, die im Handbuch zur Installation enthalten sind
- * Por cuanto respecta a recomendaciones de instalación y control ver manual de instalación

Massa e misure imballi - Packing mass and dimensions - Masse et dimensions emballages
Verpackungsmasse und-abmessungen - Masa y medidas del embalaje

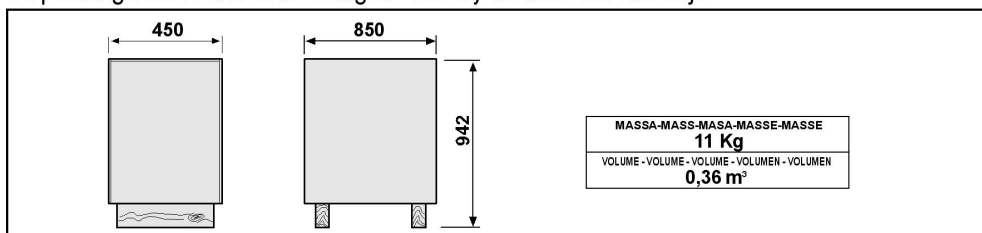

ZANOTTI S.p.A.